

Chapter 15

Extrusion and Drawing of Metals

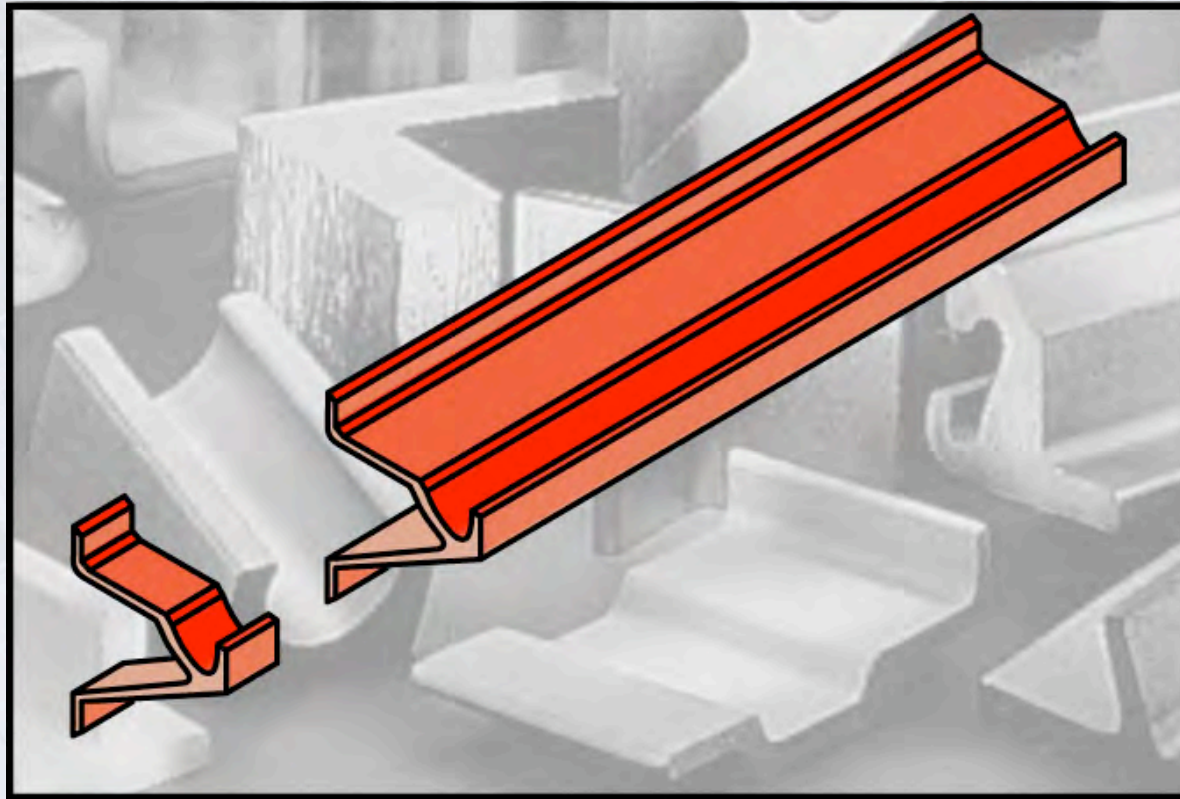

Direct-Extrusion

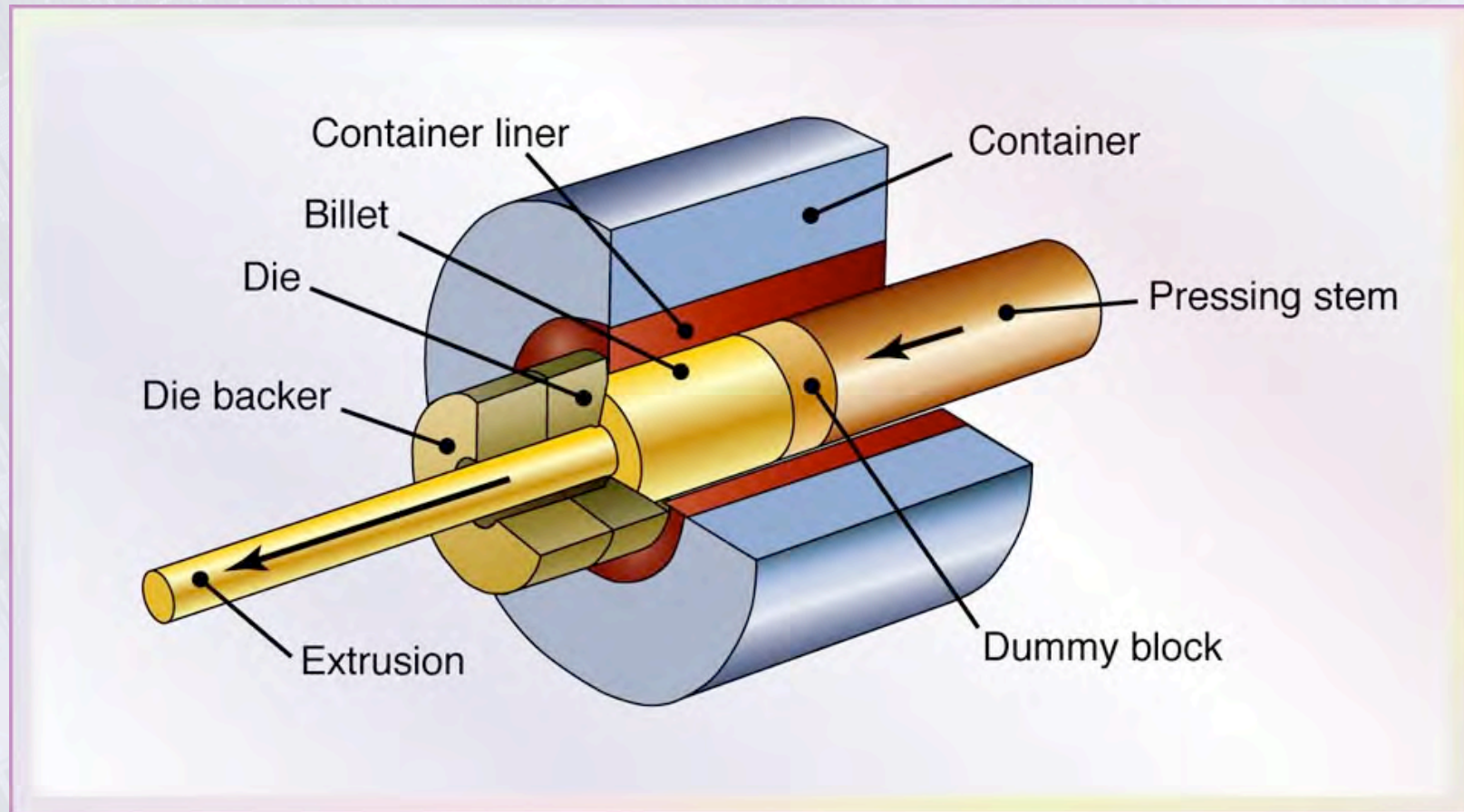

Figure 15.1 Schematic illustration of the direct-extrusion process.

Extrusions and Products Made from Extrusions

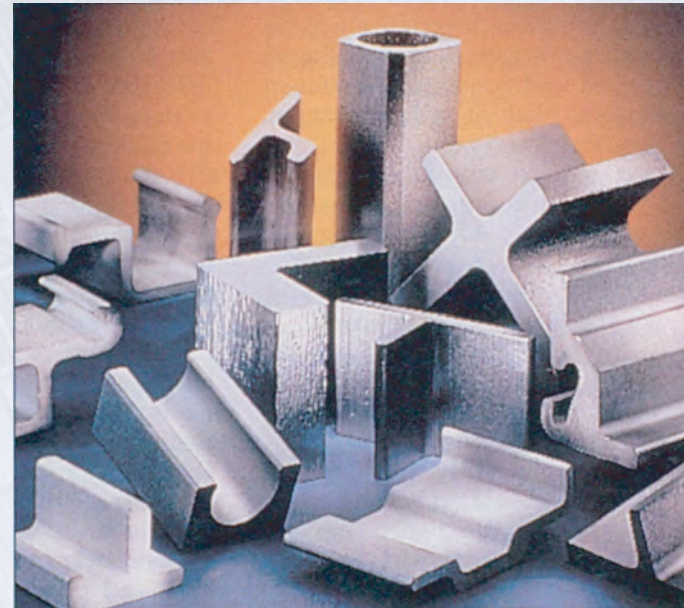
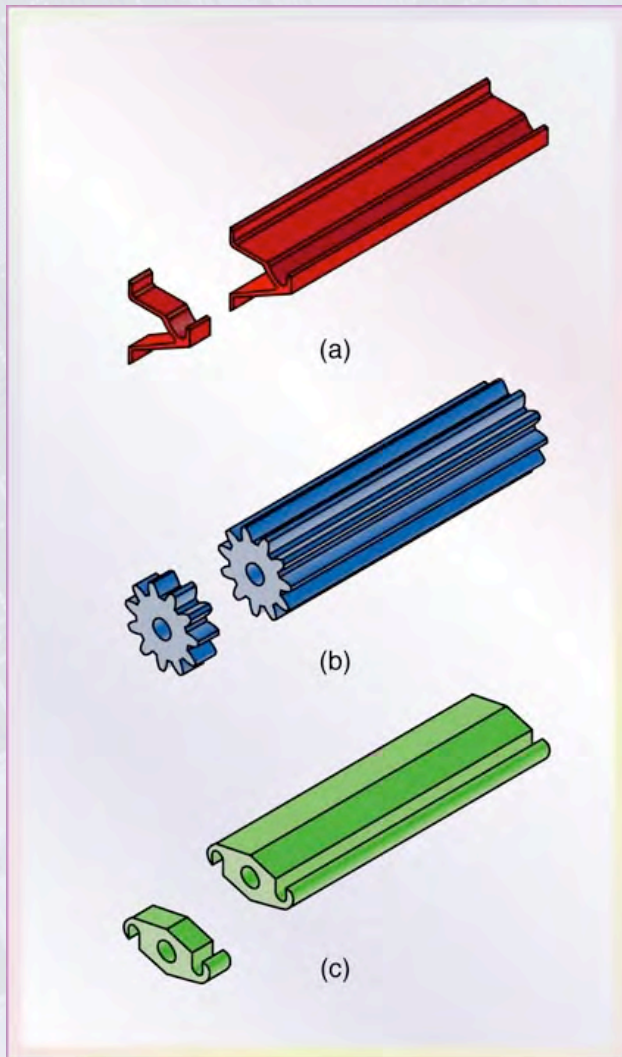

Figure 15.2 Extrusions and examples of products made by sectioning off extrusions.
Source: Courtesy of Kaiser Aluminum.

Types of Extrusion

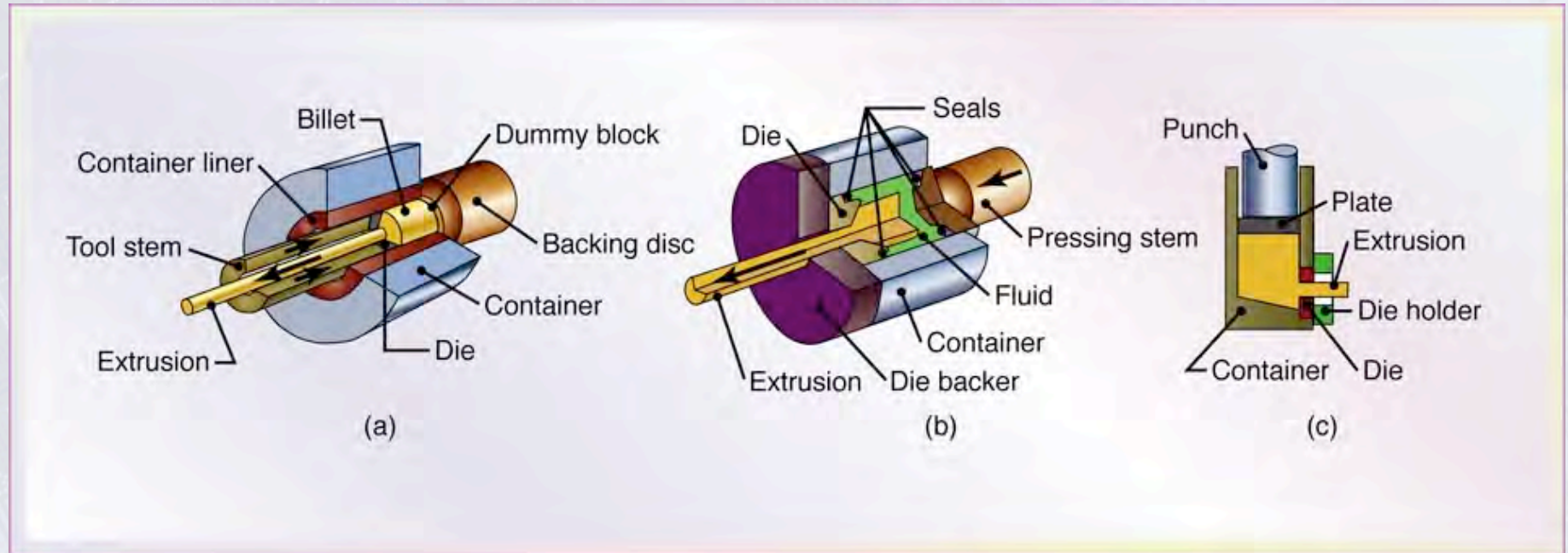

Figure 15.3 Types of extrusion: (a) indirect; (b) hydrostatic; (c) lateral;

Process Variables in Direct Extrusion

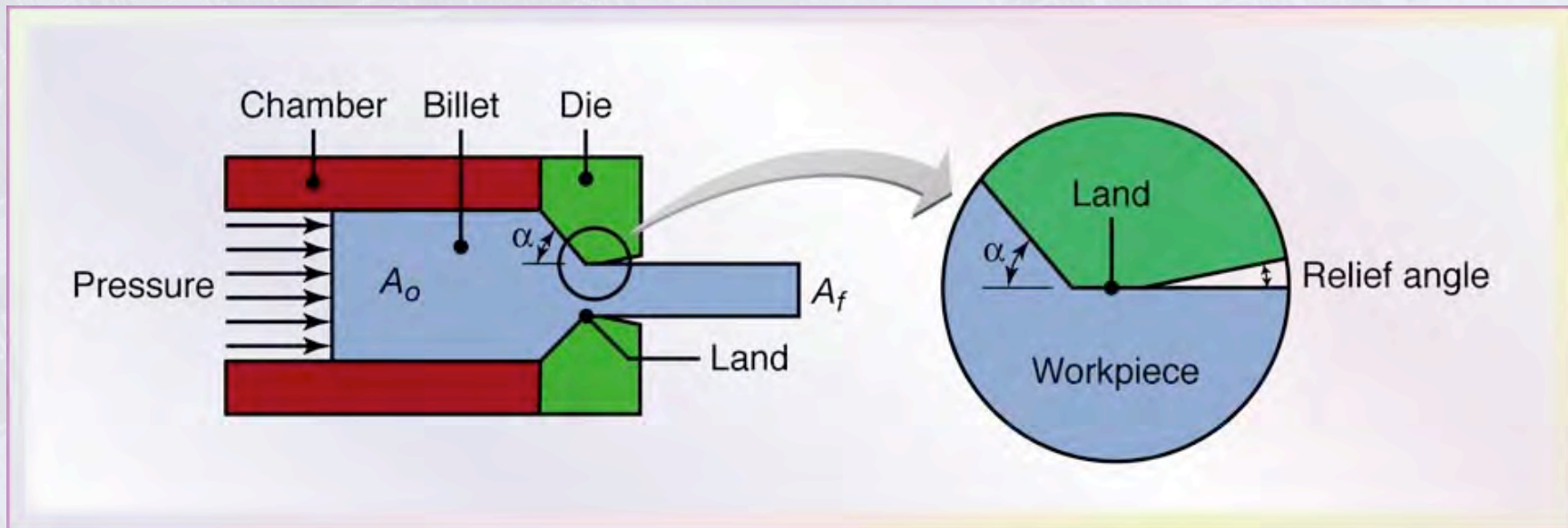
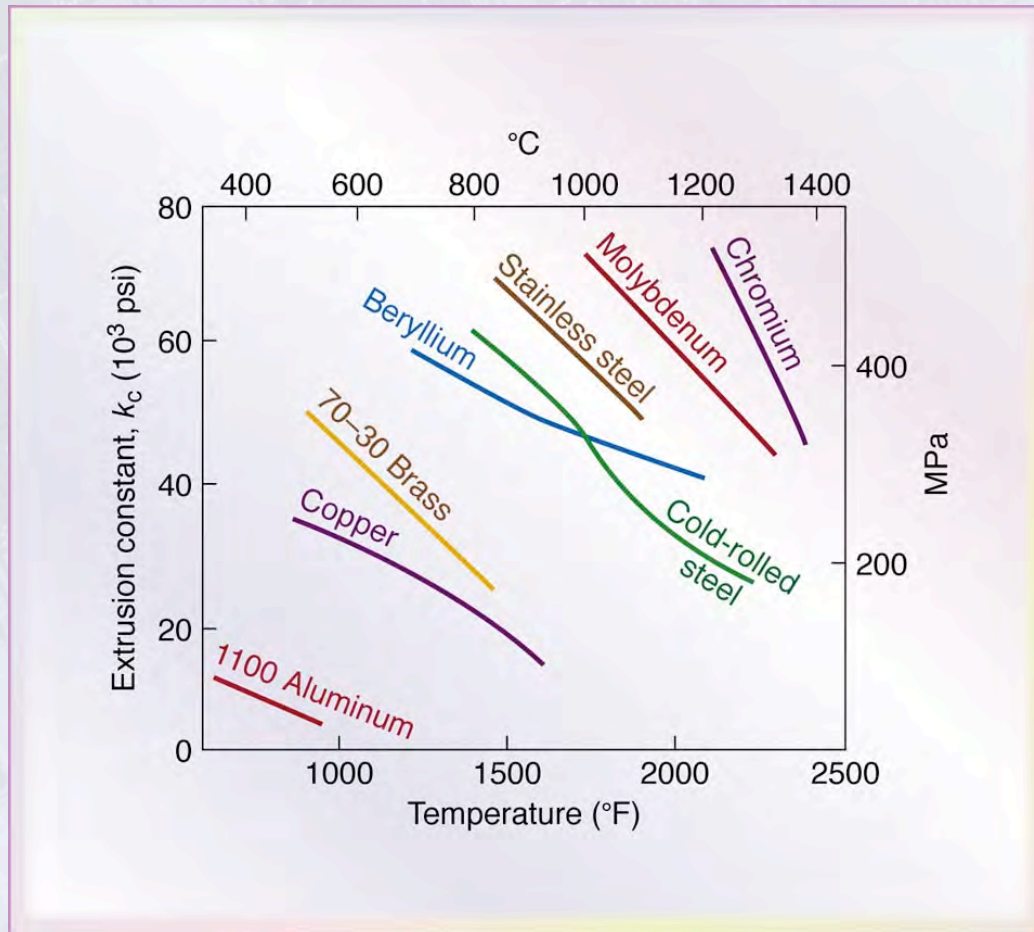

Figure 15.4 Process variables in direct extrusion. The die angle, reduction in cross-section, extrusion speed, billet temperature, and lubrication all affect the extrusion pressure.

Extrusion Force



$$\text{Extrusion force, } F = A_o l \ln \left(\frac{A_o}{A_f} \right)$$

Figure 15.5 Extrusion constant k for various metals at different temperatures. *Source:* After P. Loewenstein

Types of Metal Flow in Extrusion with Square Dies

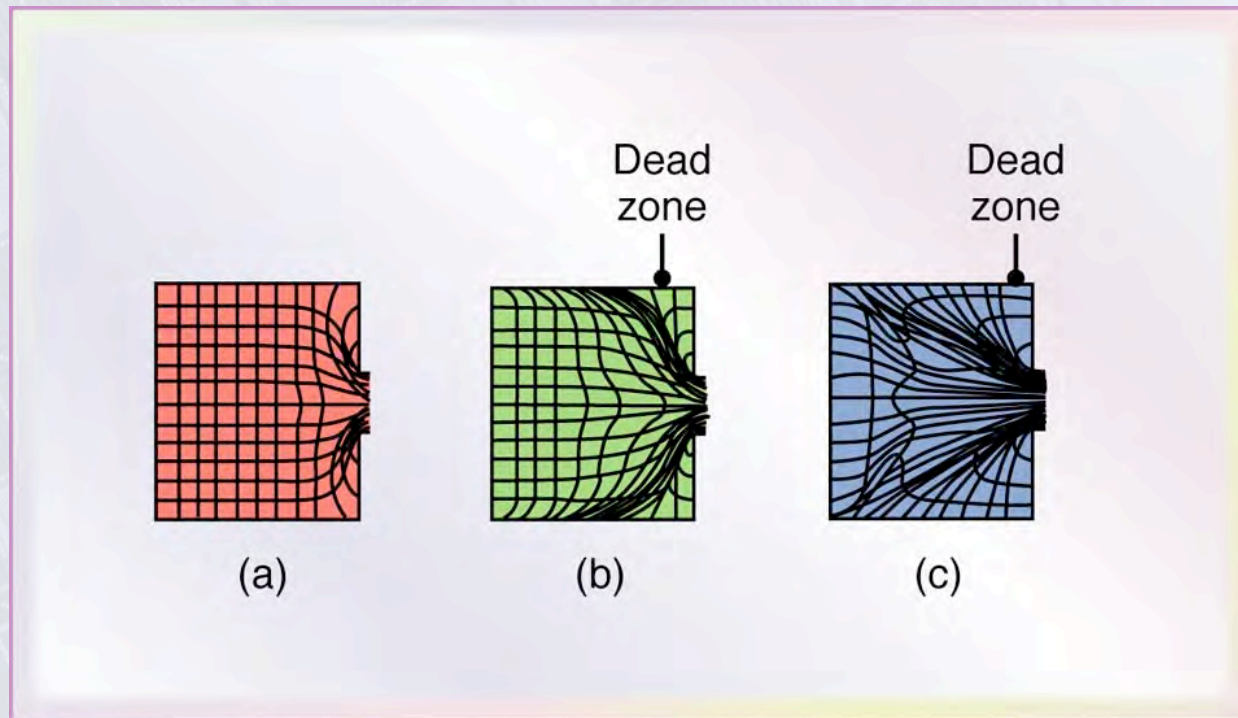

Figure 15.6 Types of metal flow in extruding with square dies. (a) Flow pattern obtained at low friction or in indirect extrusion. (b) Pattern obtained with high friction at the billet-chamber interfaces. (c) Pattern obtained at high friction or with coiling of the outer regions of the billet in the chamber. This type of pattern, observed in metals whose strength increases rapidly with decreasing temperature, leads to a defect known as pipe (or extrusion) defect.

Extrusion Temperature Ranges

TABLE 15.1

Typical Extrusion Temperature Ranges for Various Metals and Alloys

	°C
Lead	200-250
Aluminum and its alloys	375-475
Copper and its alloys	650-975
Steels	875-1300
Refractory alloys	975-2200

Extrusion-Die Configurations

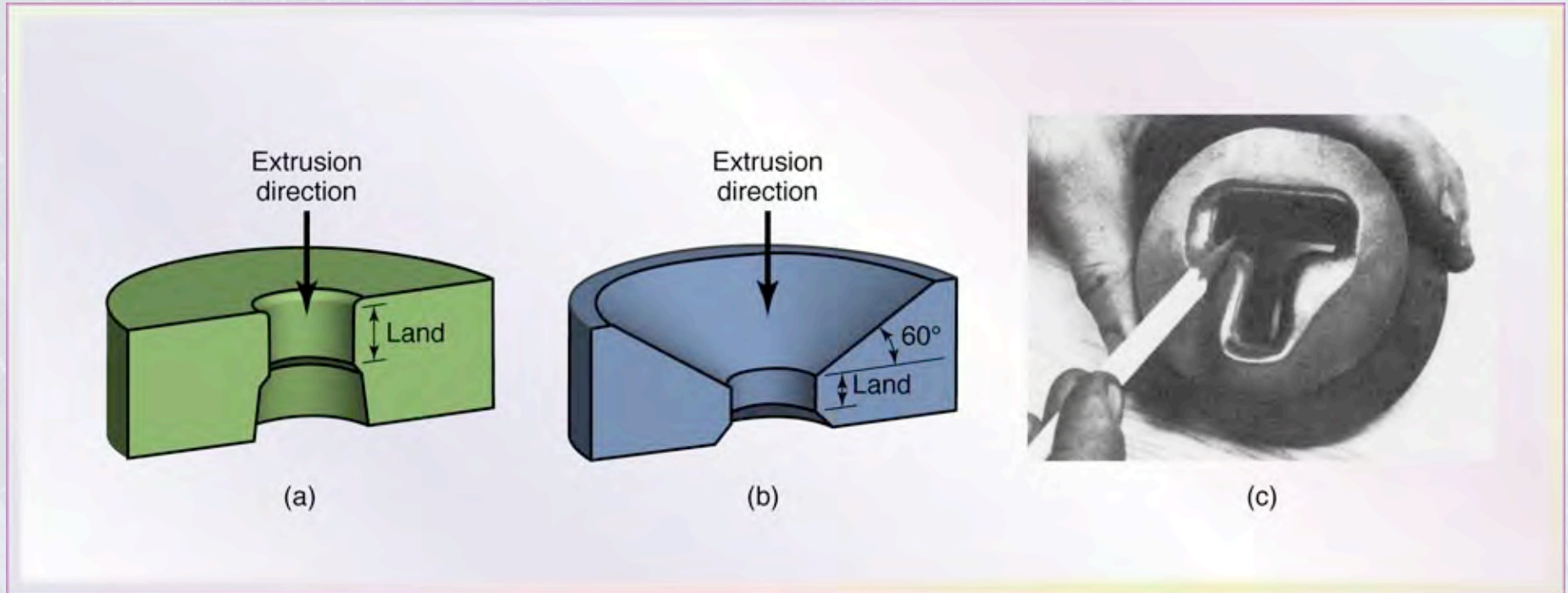

Figure 15.7 Typical extrusion-die configurations: (a) die for nonferrous metals; (b) die for ferrous metals; (c) die for a T-shaped extrusion made of hot-work die steel and used with molten glass as a lubricant. *Source:* (c) Courtesy of LTV Steel Company.

Extrusion in Creation of Intricate Parts

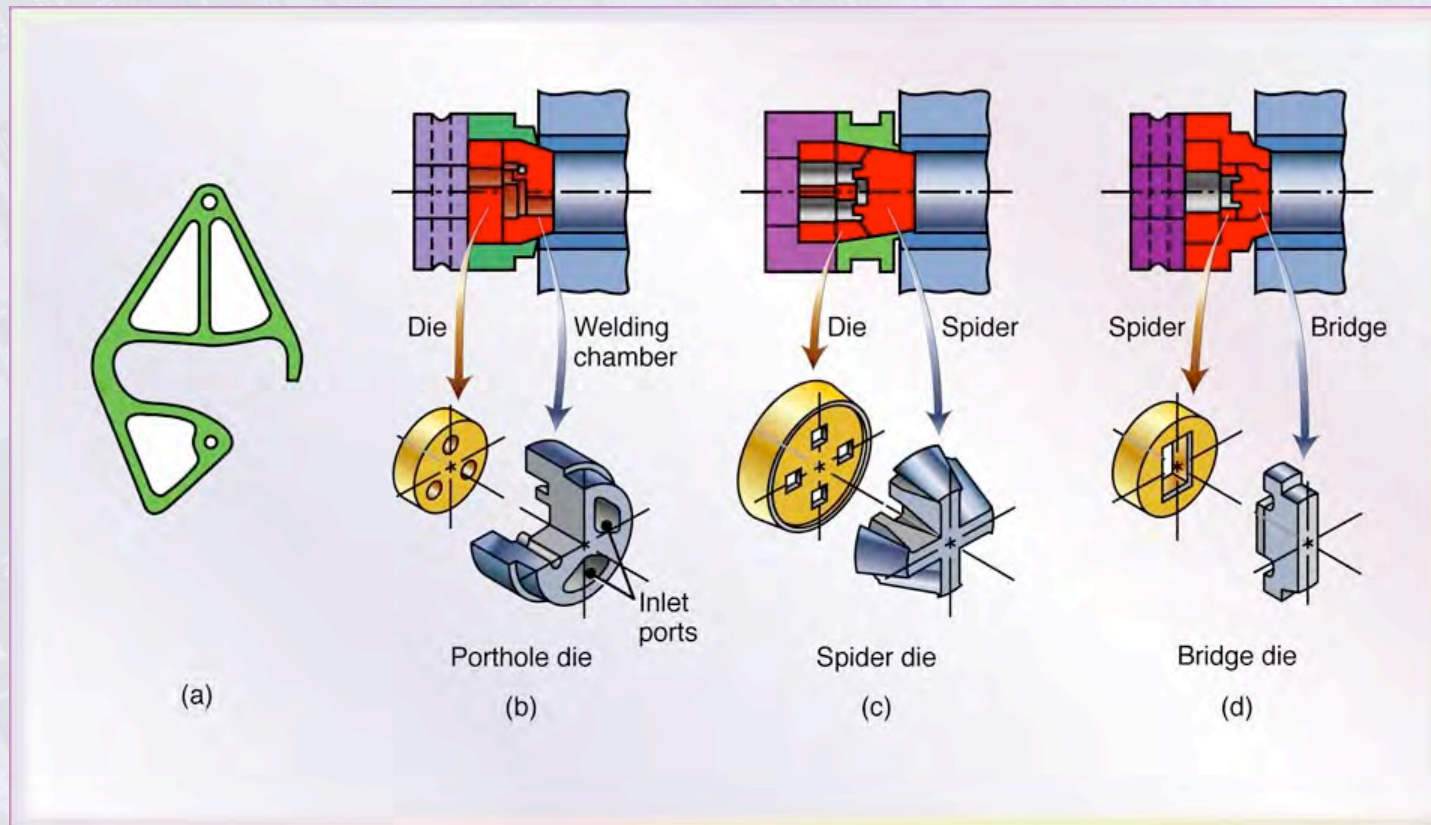

Figure 15.8 (a) An extruded 6063-T6 aluminum-ladder lock for aluminum extension ladders. This part is 8 mm (5/16 in.) thick and is sawed from the extrusion (see Fig. 15.2). (b-d) Components of various dies for extruding intricate hollow shapes. *Source:* (b-d) After K. Laue and H. Stenger

Design of Extruded Cross-Sections

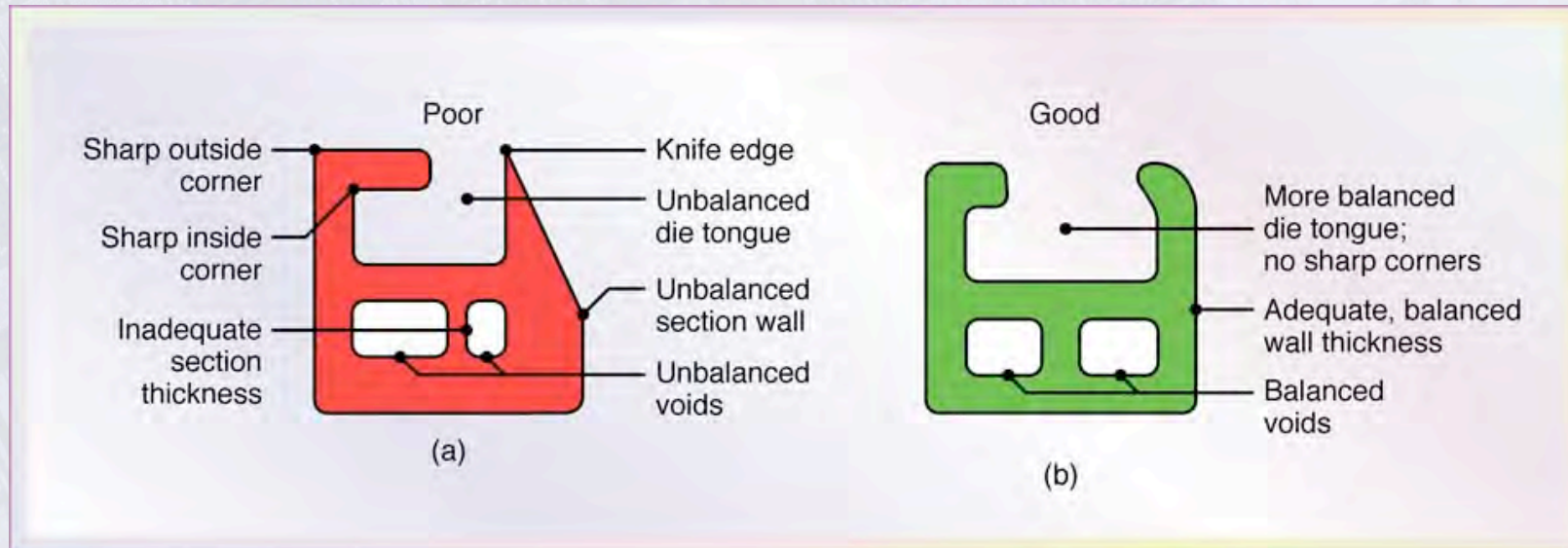

Figure 15.9 Poor and good examples of cross-sections to be extruded. Note the importance of eliminating sharp corners and of keeping section thicknesses uniform.
Source: J.G. Bralla (ed.); *Handbook of Product Design for Manufacturing*. New York: McGraw-Hill Publishing Company, 1986. Used with permission.

Extrusion of Heat Sinks

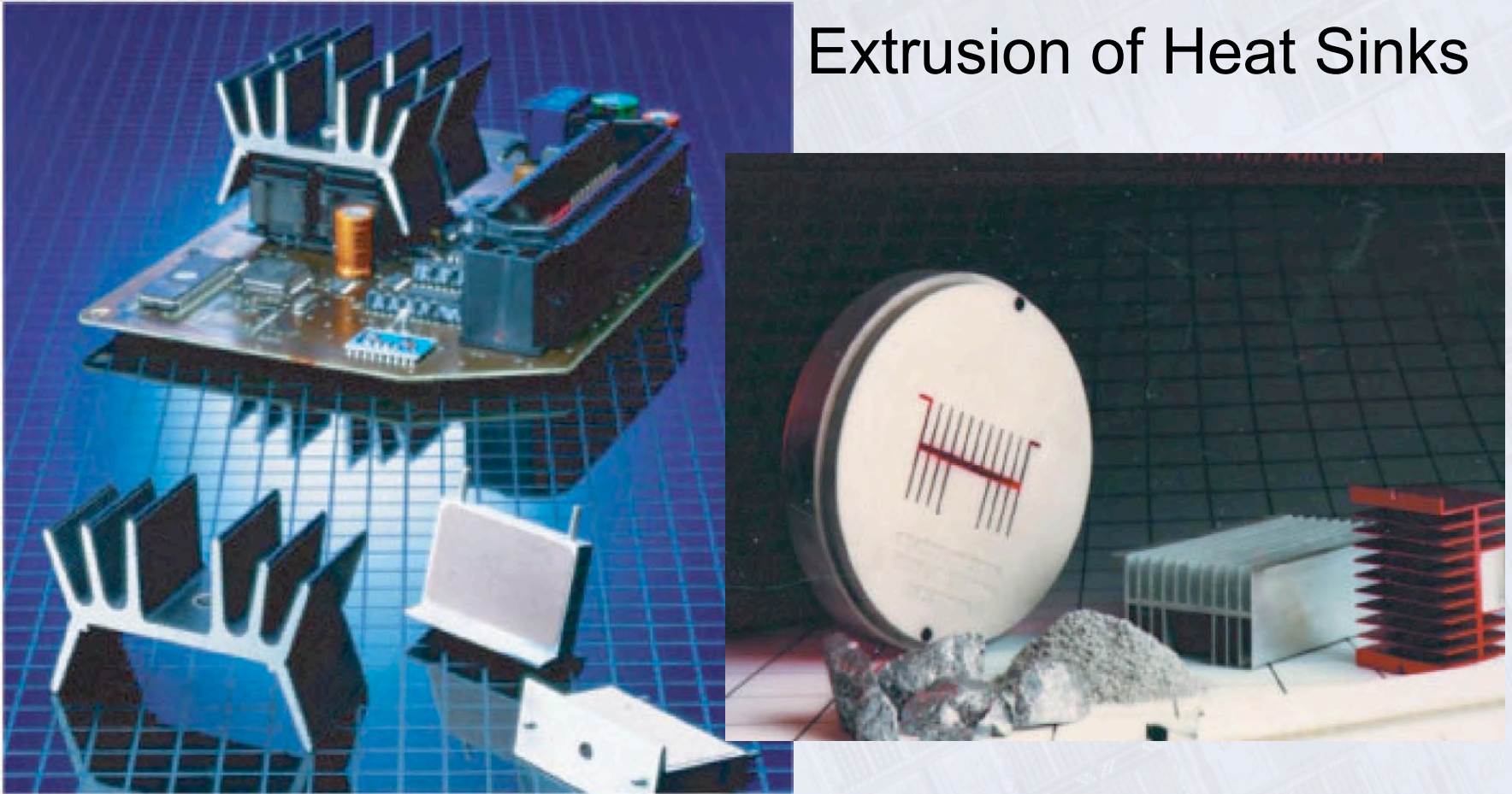

Figure 15.10 (a) Aluminum extrusion used as a heat sink for a printed circuit board. (b) Die and resulting heat sink profiles. *Source:* Courtesy of Aluminum Extruders Council.

Cold Extrusion Examples

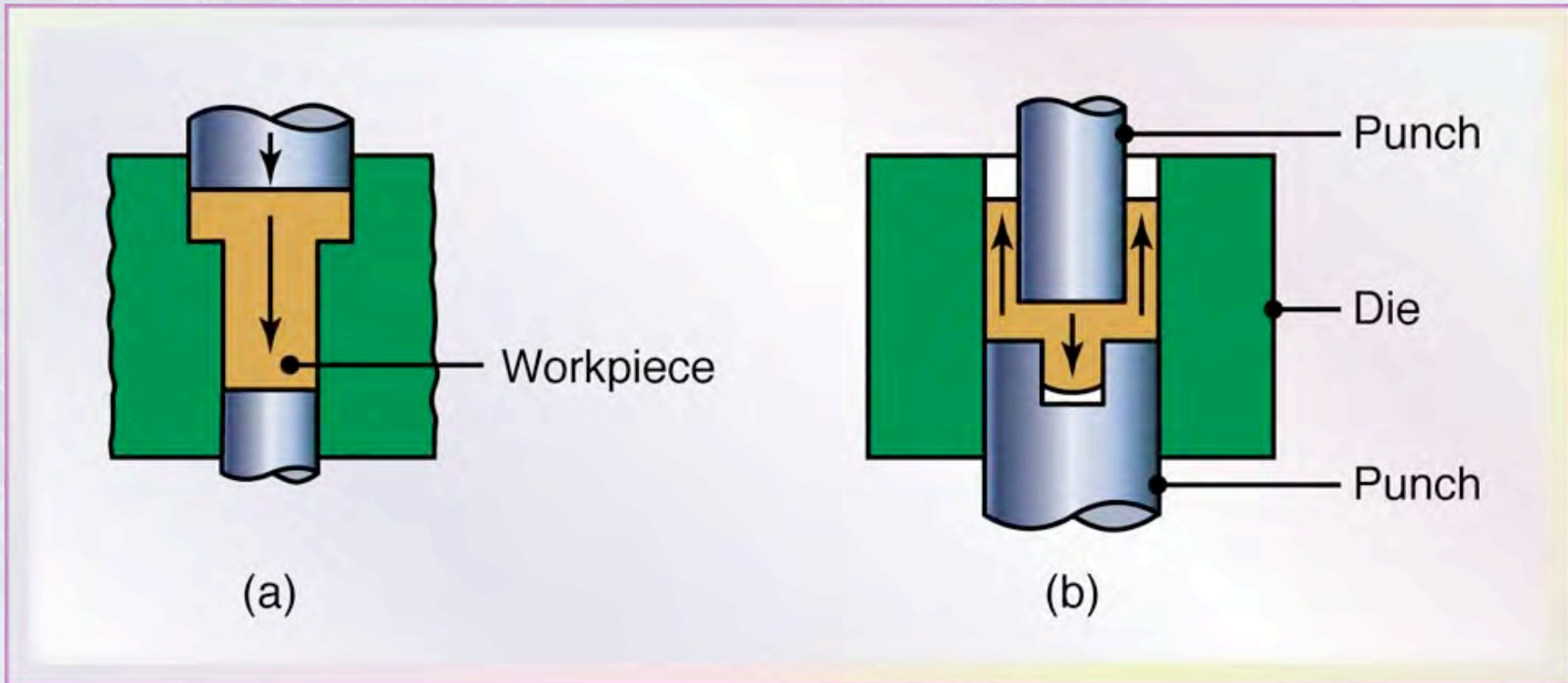

Figure 15.11 Two examples of cold extrusion. Thin arrows indicate the direction of metal flow during extrusion.

Cold-Extruded Spark Plug

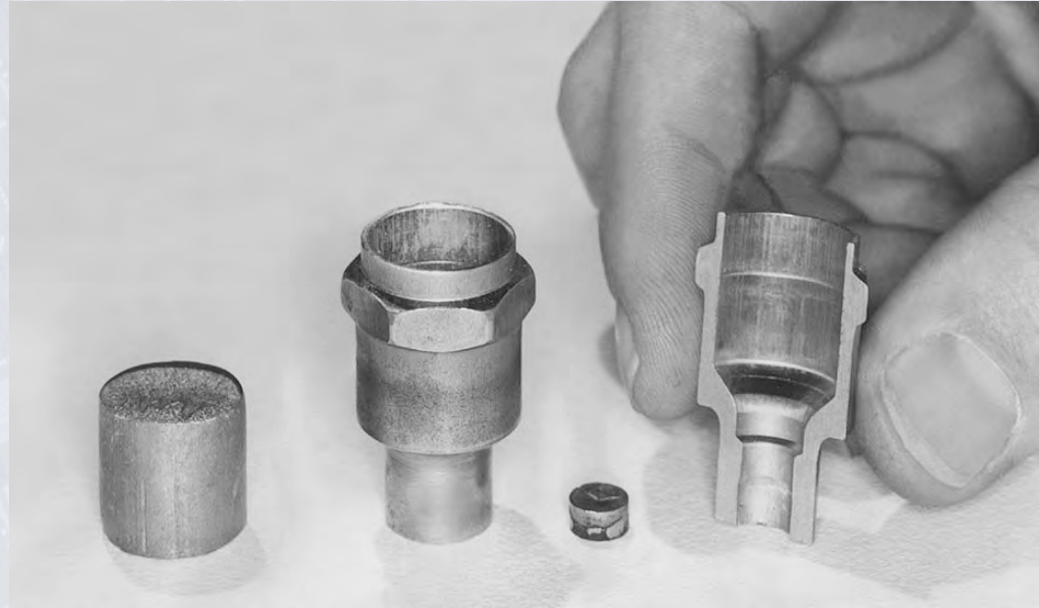

Figure 15.12 Production steps for a cold-extruded spark plug. *Source:* Courtesy of National Machinery Company.

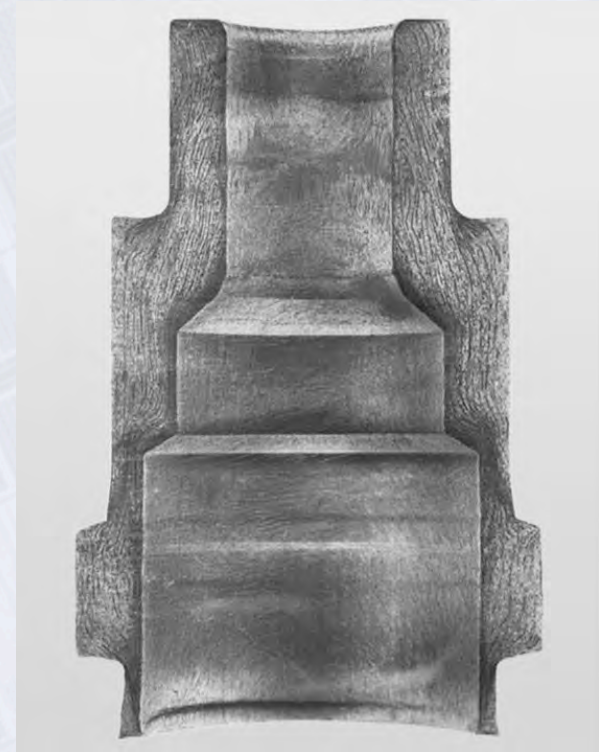

Figure 15.13 A cross-section of the metal part in Fig 15.12 showing the grain-flow pattern. *Source:* Courtesy of National Machinery Company.

Impact-Extrusion Process

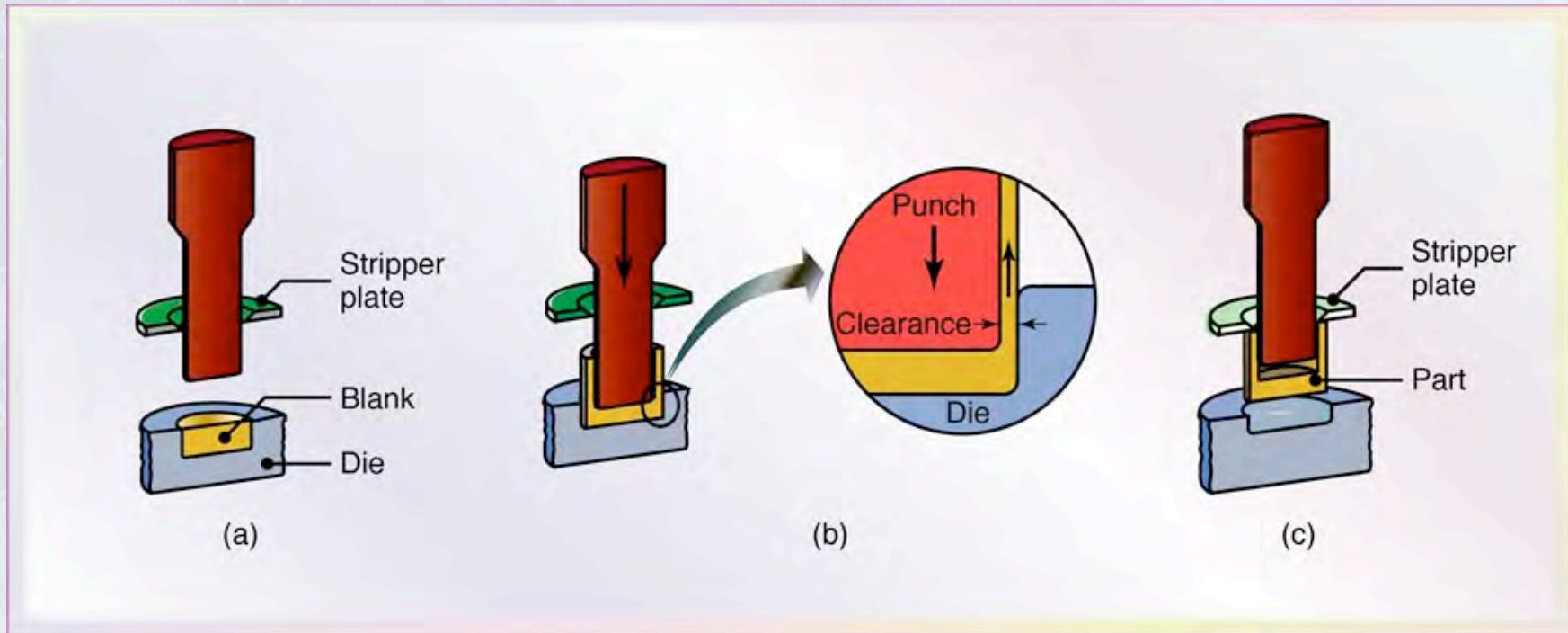

Figure 15.14 Schematic illustration of the impact-extrusion process. The extruded parts are stripped by use of a stripper plate, because they tend to stick to the punch.

Impact Extrusion

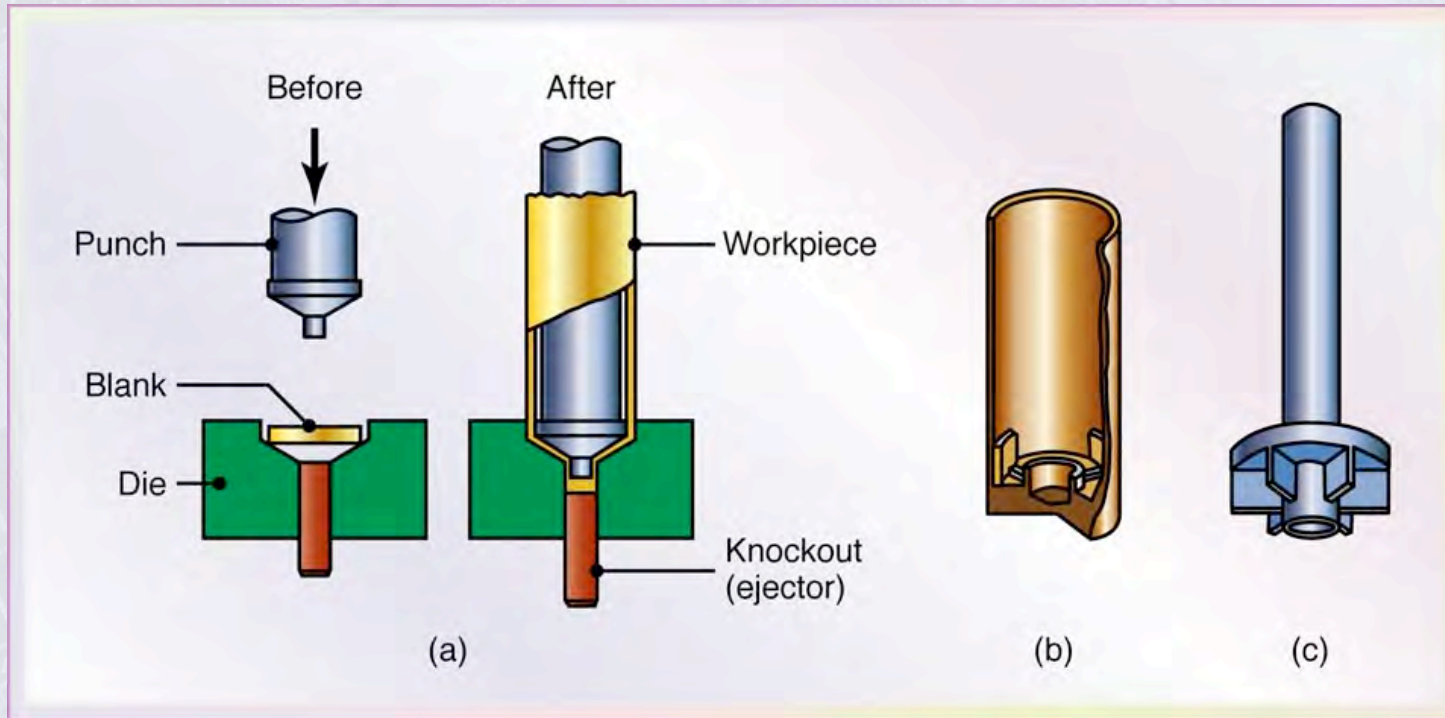

Figure 15.15 (a) Impact extrusion of a collapsible tube by the *Hooker process*. (b) and (c) Two examples of products made by impact extrusion. These parts also may be made by casting, forging, or machining. The choice of process depends on the materials involved, part dimensions, and wall thickness, and the product properties desired. Economic considerations also are important in final process selection.

Chevron Cracking

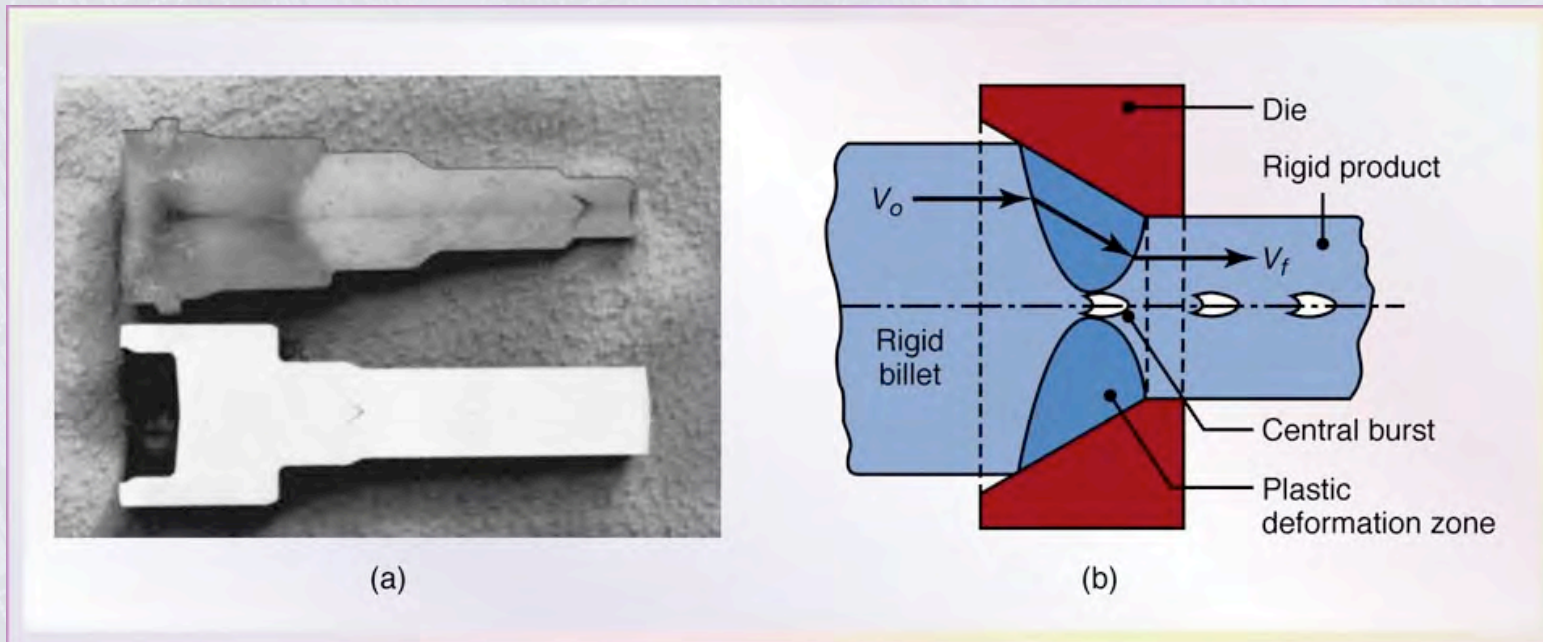

Figure 15.16 (a) Chevron cracking (central burst) in extruded round steel bars. Unless the products are inspected, such internal defects may remain undetected and later cause failure of the parts in service. This defect can also develop in the drawing of rod, of wire, and of tubes. (b) Schematic illustration of rigid and plastic zones in extrusion. The tendency toward chevron cracking increases if the two plastic zones do not meet. Note that the plastic zone can be made larger either by decreasing the die angle or by increasing the reduction in cross-section (or both). *Source:* After B. Avitzur.

9-MN (1000-ton) Hydraulic-Extrusion Press

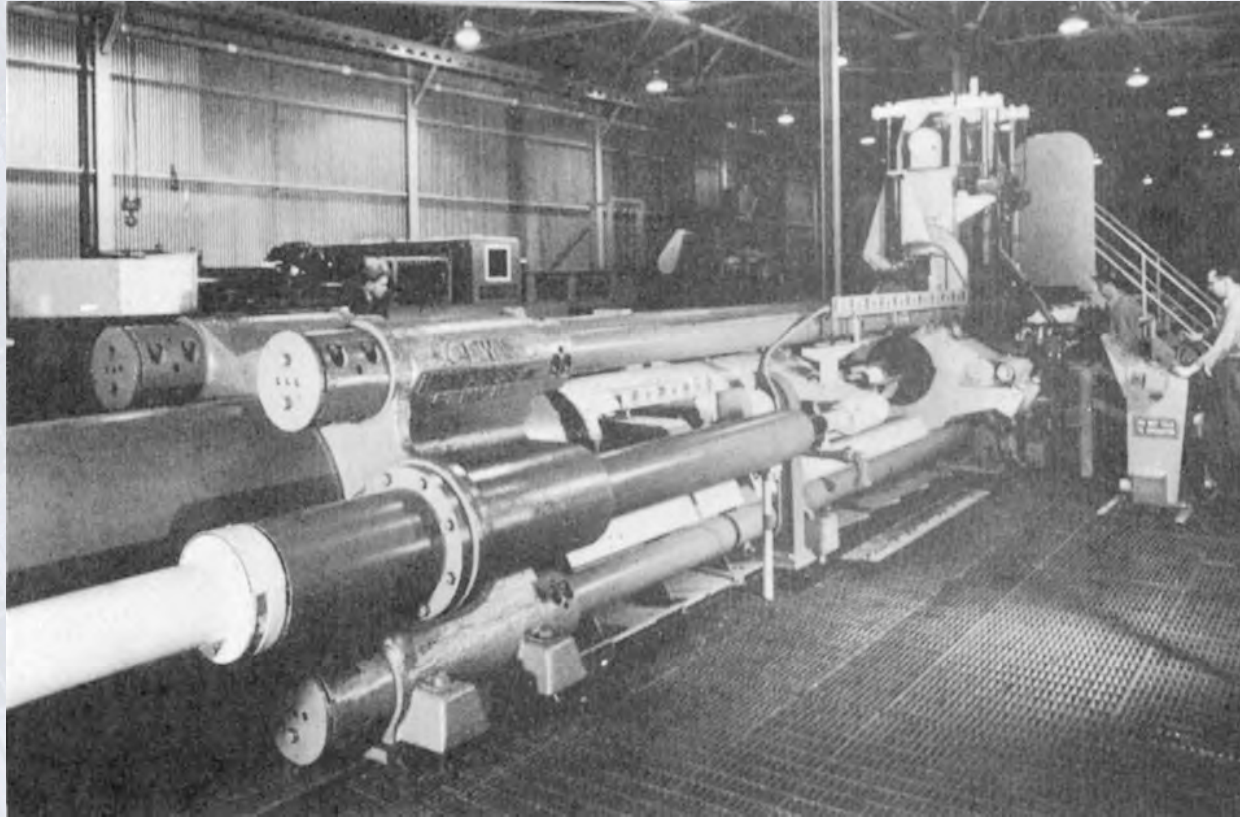

Figure 15.17 General view of a 9-MN (1000-ton) hydraulic-extrusion press.
Source: Courtesy of Jones & Laughlin Steel Corporation.

Process Variables in Wire Drawing

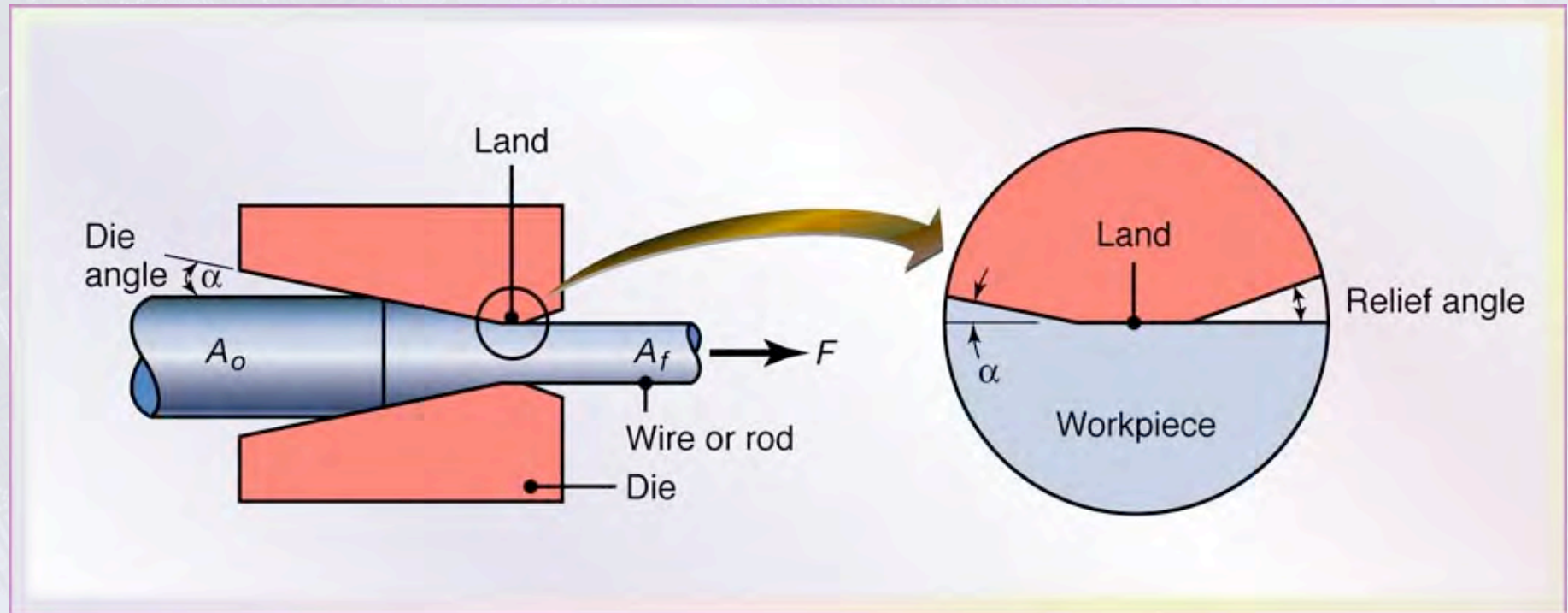

Figure 15.18 Process variables in wire drawing. The die angle, the reduction in cross-sectional area per pass, the speed of drawing, the temperature, and the lubrication all affect the drawing force, F .

Tube-Drawing Operations

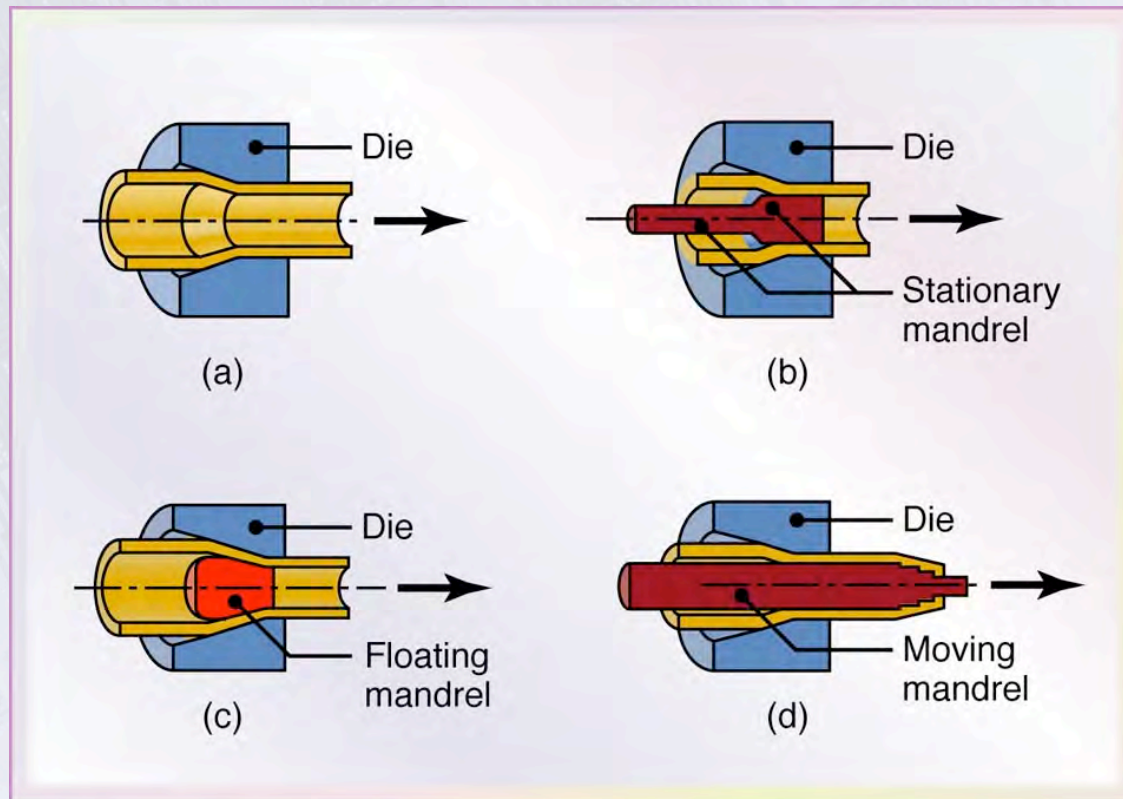

Figure 15.19 Examples of tube-drawing operations, with and without an internal mandrel. Note that a variety of diameters and wall thicknesses can be produced from the same initial tube stock (which has been made by other processes).

Drawing Dies

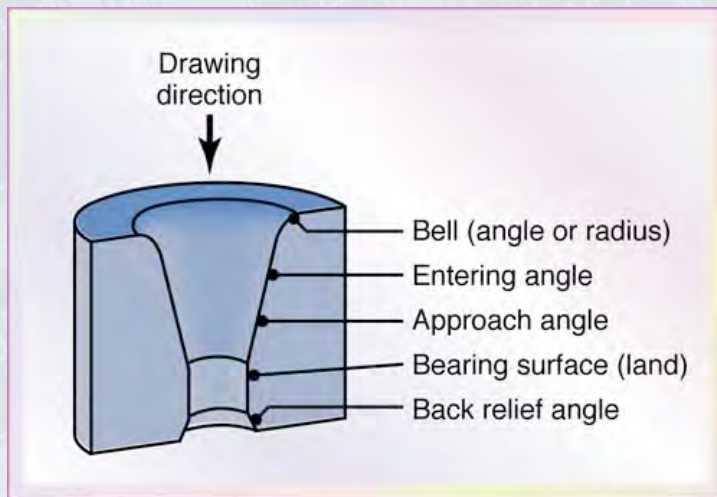

Figure 15.20 Terminology of a typical die used for drawing a round rod or wire.

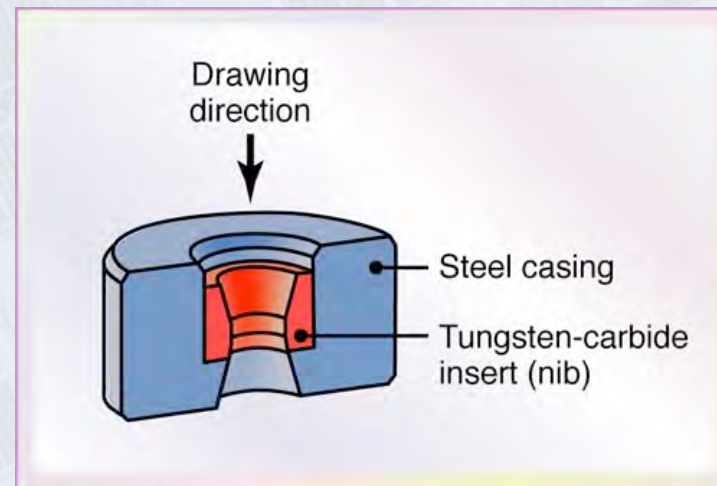

Figure 15.21 Tungsten-carbide die insert in a steel casing. Diamond dies used in drawing thin wire are encased in a similar manner.

Extruded Channel on a Draw Bench

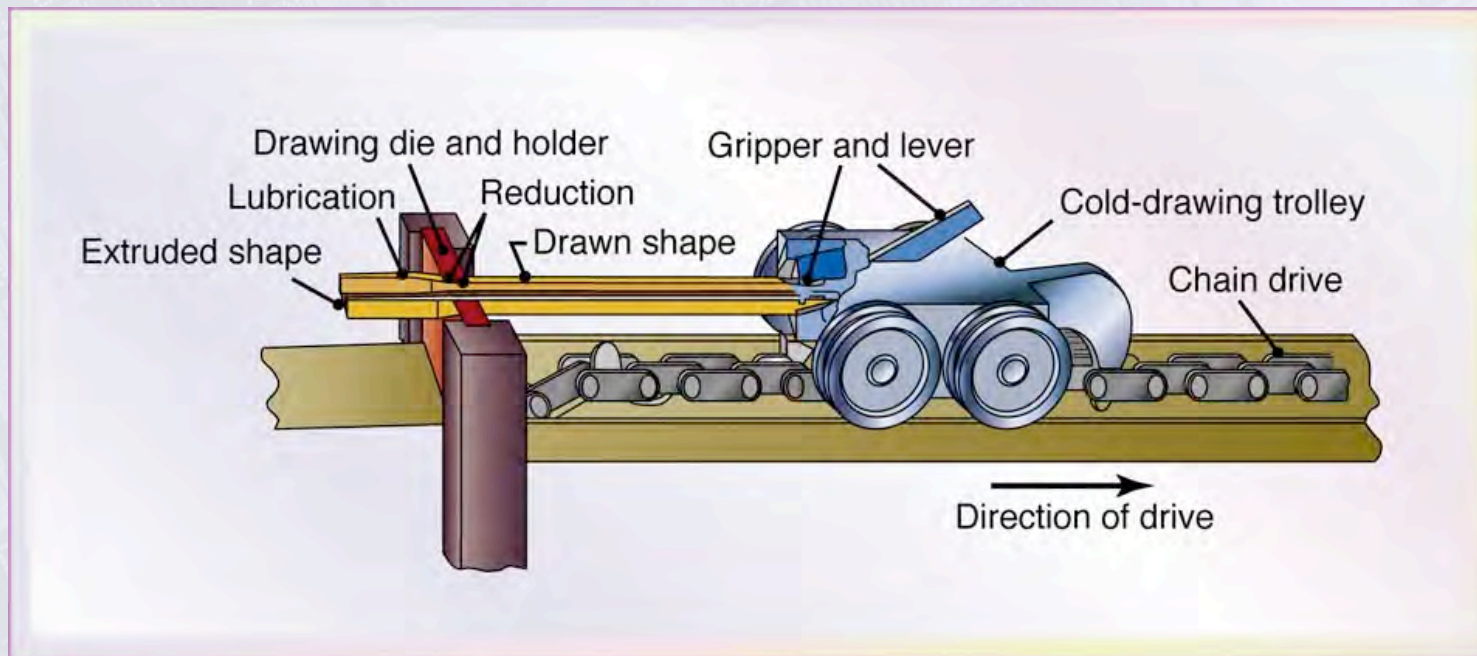

Figure 15.22 Cold drawing of an extruded channel on a draw bench to reduce its cross-section. Individual lengths of straight rods or of cross-sections are drawn by this method. *Source:* Courtesy of The Babcock and Wilcox Company, Tubular Products Division.

Multistage Wire-drawing Machine

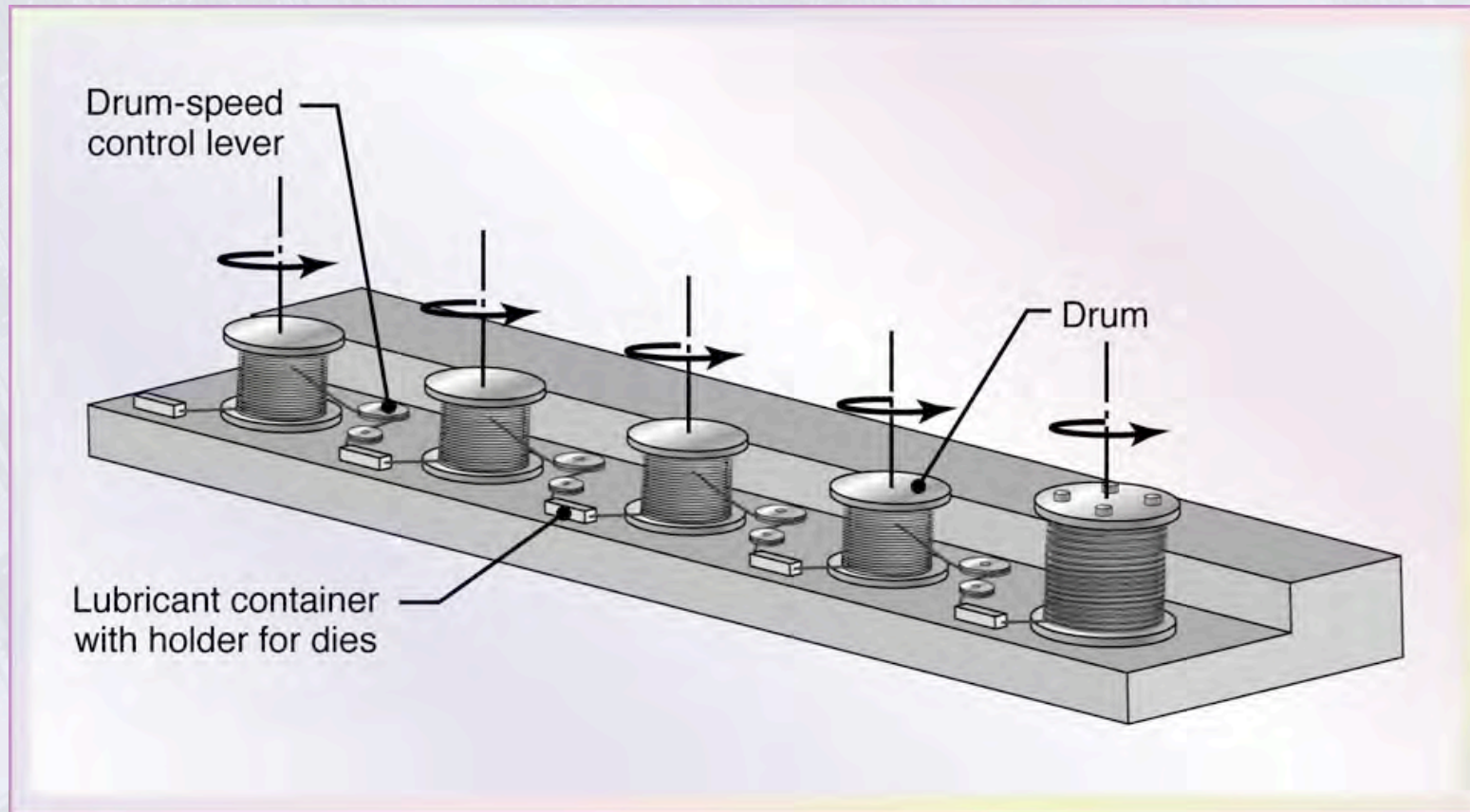

Figure 15.23 Two views of a multistage wire-drawing machine that typically is used in the making of copper wire for electrical wiring. *Source:* After H. Auerswald